

YourTable Switch

The all-rounder at the POS



YourTable Switch

■ **YourTable Switch is the perfect all-rounder** to create more attention and more flexibility at the POS. This sales system always presents your products on offer in a unique, exciting and varied way – customers will find it hard to resist.

The YourTable Switch is a table, shelf and tiered display stand all-in-one.

This unique multi-functionality of the YourTable Switch is made possible by its smart design, which allows effortless conversion for flexible use with its practical accessories.

It is this which makes it a valuable tool on the sales floor. You will be impressed by the YourTable Switch.



- *Table, shelf and tiered display stand*
- *Flexible adaptation to different product groups*
- *Mobile for quick changes of location*
- *Customised colour and finish combinations*



YourTable Switch

One system – many possibilities



■ **YourTable Switch boosts additional sales** and makes cross-selling a cinch. Designed as a presentation staircase, it gives fruit and vegetables, but also herb pots, fine dressings or nuts a striking stage. Customers will find it hard to resist.

■ **With its warm wood finishes** and sophisticated metal surfaces, the YourTable Switch becomes a focal point as a presentation table.. Refined product combinations or highlights from your wine section can be perfectly arranged and highlight your product range expertise.



YourTable Switch

Flexible adaptation – the wild card at the POS



■ **It is a well-known fact that the checkout area shapes the last impression.** A good reason, therefore, to bid customers farewell with an attractive flower presentation. This, of course, is a job for the YourTable Switch and its handy inserts to skilfully generate an impulse to buy over the last few metres in the store.



■ **The YourTable Switch is perfect as a shelf** and the bulk goods inserts are also ideal for the drugstore section. Product range highlights and special offers will thus attract a lot of attention from buyers.



YourTable Switch

■ **Thanks to its ingenious construction**, the YourTable Switch can be converted to the desired presentation system without the use of tools in next to no time in just a few steps. Thanks to the convenient tilting mechanism, your product presentation is always at its best.



IN JUST A FEW STEPS,
convert from a sales table to a presentation table to a shelf

More customisation

High-quality surfaces, interesting mix of materials – the wide variety of colour variants and finishes for the YourTable Switch provide a lot of scope for individuality.



Variable inserts

From wire or wicker baskets, wooden shelves to flower inserts, the YourTable Switch can be optimally adapted to your product category.



■ The shelf can be adjusted to 0°, 17.5°, 30° angles.



FOR OPTIMAL PRESENTATION,
shelf inclinations can be adjusted

Intelligent pinch protection

The YourTable Switch protects hands and fingers.
A smart protective mechanism offers maximum
protection from injuries.

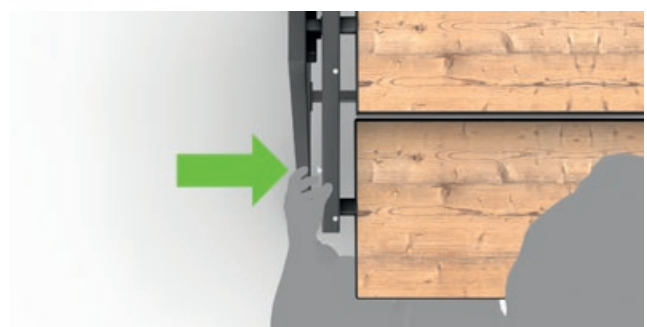

Quick changes of location

The YourTable Switch is fitted with smooth-running
castors. Changes of location within the store are
therefore done in a jiffy. This saves valuable time.



YourTable Switch order section



YourTable Switch order section

Basic framework	Dimensions	Prod.No.	colour/finish
YourTable Switch – without inserts	1069 x 698 x 858	37.46350.95	----
1 YourTable Switch – flat-packed variant without inserts	1069 x 698 x 858	37.46358.95	----
Accessories			
2 Double-sided blister panel for advertising panel	985 x 250	37.46363.73	----
Perforated sheet double hook, short	150	35.32143.00	
Perforated sheet double hook, long	250	35.78482.00	
3 Advertising board for advertising panel	985 x 245	auf Anfrage	
4 Advertising panel	1034 x 875	37.46362.73	----
5 Polyrattan basket (beige) incl. dirt tray	800 x 300 x 60	37.46366.95	----
Polyrattan basket (anthracite) incl. dirt tray	800 x 300 x 60	37.46367.95	----
Polyrattan basket (brown) incl. dirt tray	800 x 300 x 60	37.46368.95	----
6 Wooden insert	800 x 300 x 19	37.46355.95	----
7 Front grate for wooden insert	800 x 30	37.46353.73	----
8 Basket and bucket holder	800 x 300	37.46351.73	----
9 Black plastic bucket	240 x 260	12.20249.07	0000
Round polyrattan basket	300 x 270	37.46103.07	----
10 Wire hanging basket	800 x 300 x 100	37.46352.73	----
Scanner rail, magnetic	800 x 39	37.46354.07	9091
Scanner rail for front grate	70 x 40	35.21598.07	0000
11 Advertising board	985 x 245	37.46357.95	----
12 Magnetic foil for advertising panel	975 x 245	on request	

Colours / finishes

Colours

9010	Pure white
9160	Metallic grey frame
7097	Anthracite metallic

Wood finishes

0359	Bramberg spruce
0427	Natural Halifax oak
0200	Premium white

Polyrattan basket finishes

7097	Anthracite
1001	Beige
8017	Brown

Order tip:

Please choose your colour or finish!	
Prod.No.	colour / finish
37.46342.62	----

Dimensions

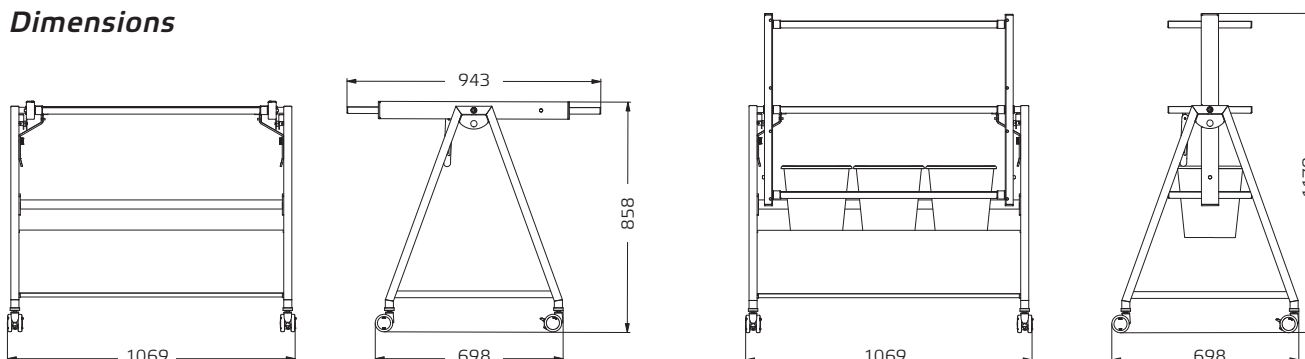

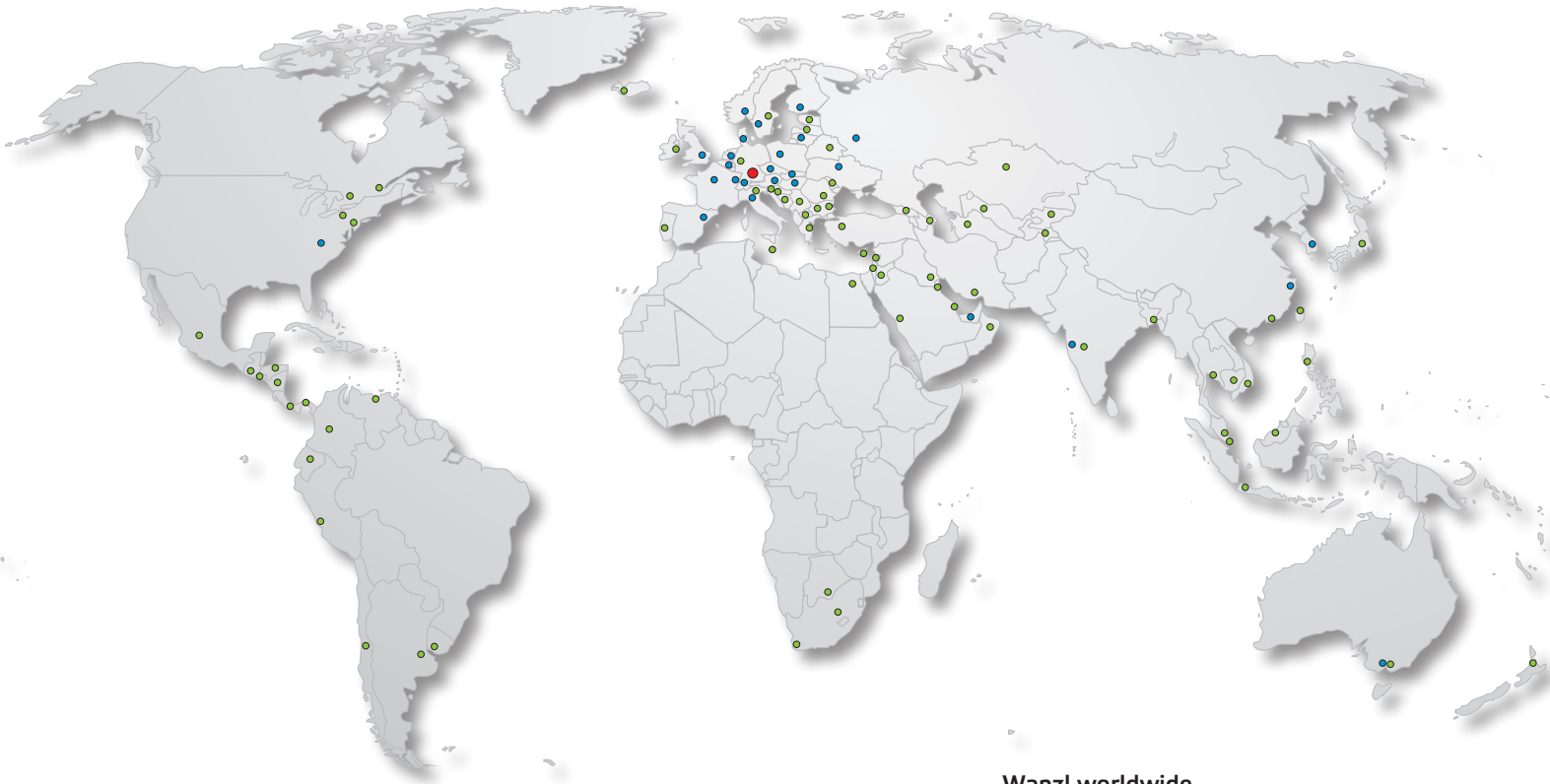

Wanzl worldwide

- Head Office
- Subsidiaries
- Partners



GERMANY

Wanzl GmbH & Co. KGaA
Rudolf-Wanzl-Straße 4
89340 Leipheim

Phone +49 (0) 82 21 / 7 29-0
Fax +49 (0) 82 21 / 7 29-1000

info@wanzl.com
www.wanzl.com

GREAT BRITAIN

Wanzl Ltd.
Europa House
Heathcote Lane
Warwick CV34 6SP

Phone +44 (0) 1926 / 45 1951
Fax +44 (0) 1926 / 45 1952

enquiries@wanzl.co.uk
www.wanzl.com

AUSTRALIA

Wanzl Australia Pty. Ltd.
97 Highbury Road
BURWOOD VIC 3125

Phone +61 (0) 3 / 98 08 22 99
Fax +61 (0) 3 / 98 08 22 66

info.au@wanzl.com
www.wanzl.com